

ALL DIMENSIONS IN MILLIMETRES
REMOVE ALL SHARP EDGES

THIRD ANGLE PROJECTION
DO NOT SCALE DRAWING

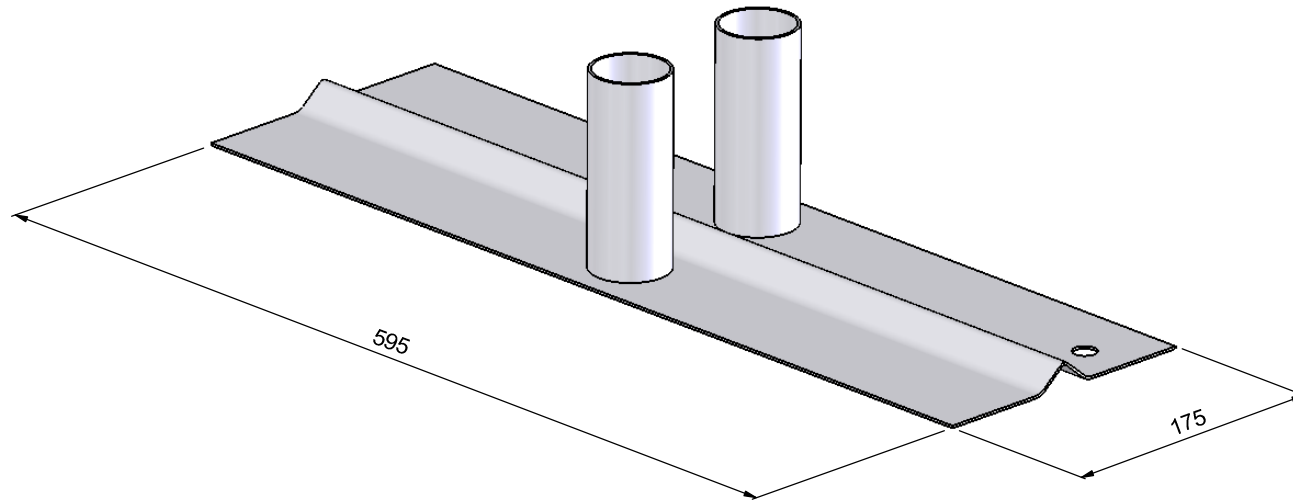

2	2/1/14	ISSUED FOR MANUFACTURE	GC		
1	15/3/12	ISSUED FOR MANUFACTURE	GC		
REV	DATE	DESCRIPTION	DRN	CHKD	APPR

TOLERANCES - UNLESS STATED OTHERWISE		
UNTOLERANCED DIMENSIONS	+/- 2mm	
CUTTING LENGTHS	+/- 2mm	
FABRICATION	UP TO 300mm	+/- 1mm
	UP TO 1000mm	+/- 2mm
	1001mm & ABOVE	+/- 3mm
	ANGULAR	+/- 1°
MACHINING	+/- 0.2mm	
GAUGE	+/- 10%	
WEIGHT	+/- 10% (DUE TO MATERIAL PROPERTIES & TOLERANCES)	

TITLE: DOUBLE FLAT METAL FOOT FEMALE - PRE-GALV			
NAME	SIGNATURE	DATE	MATERIAL:
G. CRICK		20/5/8	CARBON STEEL PRE-GALVANISED
CHK'D			
FINISH: NONE			



EURO Doppelfussmetall - 1088

THE COMPANY RETAIN THE RIGHT TO PERIODICALLY ALTER INFORMATION WITHIN THIS DRAWING SHEET AND WILL ATTEMPT TO NOTIFY ALL PARTIES CONCERNED OF ANY CHANGES AND THE INFORMATION ON THIS SHEET SHOULD NOT BE REPRODUCED WITHOUT THEIR WRITTEN CONSENT.

Drw / Stockcode No.

13052530

Revision

2

WEIGHT: 1.8 Kg

SCALE: 1:3

SHEET 1 OF 9

A3