

SAFEGATE

The Safegate is a barrier system designed to be used around manhole repairs, cable laying and other temporary excavations.

Features

- Safegate barrier system comprises a set of high-visibility, hinged gates – individual barrier weighs only 4.4lbs
- Can also be used to protect any area requiring temporary restriction of access, such as wet floors or cleaning work in progress
- Modular design means the barrier can be configured in a number of different ways
- Hinged clips enable fast, simple assembly in 4-way configurations
- Integral locking clamp to aid stability when the barriers are deployed in a straight line
- Lightweight barrier – folds for easy transportation and storage
- Made from HDPE
- Designed and manufactured in UK
- 100% recyclable



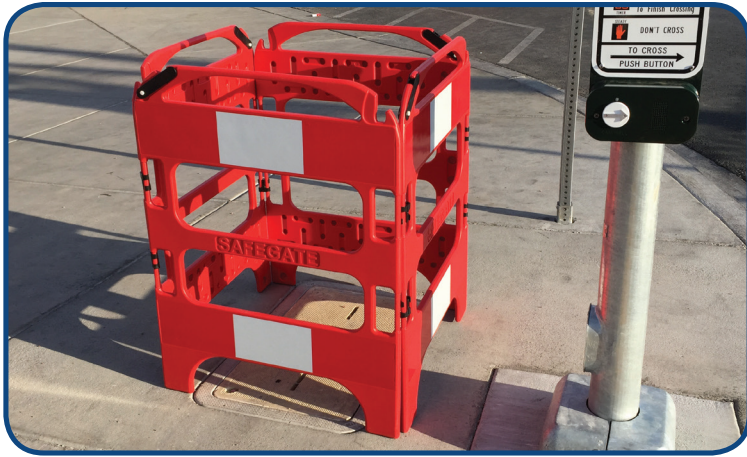

SAFEGATE 4WAY

- Product No** 09738
- Length single gate** 29.5"
- Total length** 118.1"
- Height** 39.4"
- Weight** 17.6lbs
- Number per pallet** 20
- Color** Red, Yellow

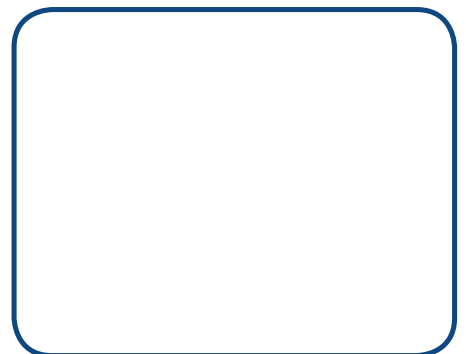
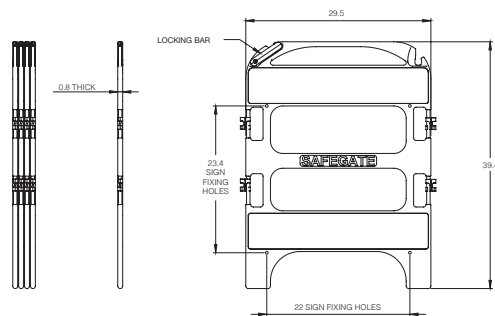

**Safegate 4Way
20 per pallet**

